

REVISIONS				
REV.	DESCRIPTION	E.C.O. NO.	DATE	APPROVED
XX	XX	XX	XX	

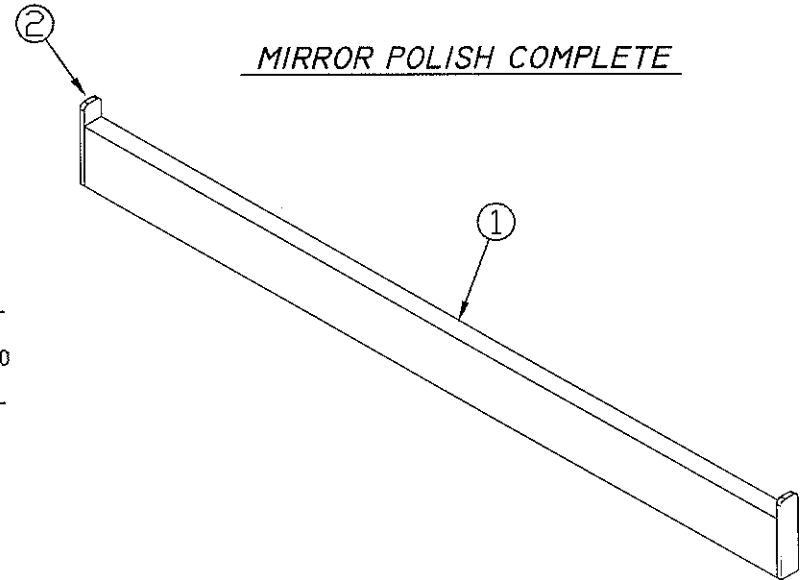
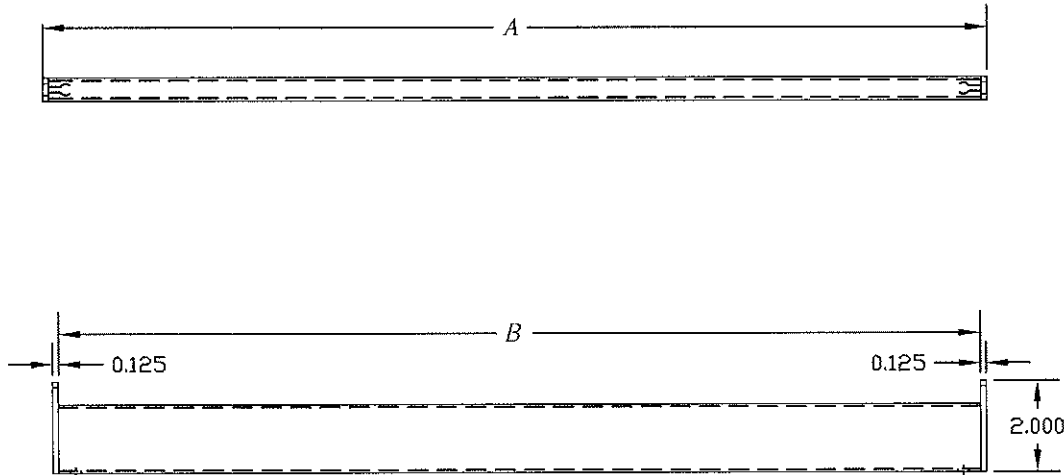

MIRROR POLISH COMPLETE

---	24.000	23.750	NS0055	SATIN NICKEL
128706	36.875	36.625	NS0056-36-SN	SATIN NICKEL
128707	46.875	46.625	NS0057-48-SN	SATIN NICKEL
128708	58.875	58.625	NS0058-60-SN	SATIN NICKEL
128709	71.875	71.625	NS0064-72-SN	SATIN NICKEL
128710	29.375	29.125	NS0067-30-SN	SATIN NICKEL
---	50.000	49.750	NS0133	SATIN NICKEL
---	16.000	15.750	NS0134	SATIN NICKEL
124690	36.875	36.625	NS0056-36-PC	P/CHROME
124691	46.875	46.625	NS0057-48-PC	P/CHROME
124692	58.875	58.625	NS0058-60-PC	P/CHROME
128343	71.875	71.625	NS0064-72-PC	P/CHROME
128341	29.375	29.125	NS0067-30-PC	P/CHROME
124700	71.875	71.625	NS0064-72-BS	BRONZE SHIMMER
126228	29.375	29.125	NS0067-30-BS	BRONZE SHIMMER
EQCB No.	A	B	PART #	FINISH

2	R251	.125 X .500 X 144" CR BAR	CHART	2
1	R197	16-GA. X 1/2" X 1-1/2" TUBE	CHART	1
ITEM	PART NO.	DESCRIPTION	LENGTH	QTY.
BILL OF MATERIALS				
UNLESS OTHERWISE SPECIFIED DIMENSIONS ARE IN INCHES TOLERANCES ARE:		CUSTOMER MERVYNS		
FRACTIONS: ± 1/32	DECIMALS: .XX ±.01 .XXX ±.005	ANGLES: ± 1/2°	APPROVALS: _____ DATE: _____ DRAWN: J. AVILA 05-16-06	
FINISH SEE CHART		CHK'D: _____	TITLE NS0056,57,58,64,67	
DO NOT SCALE DRAWING		APP'D: _____	SIZE B	DWG. NO. 4000158
		EQCB NO. SEE CHART	SCALE N.T.S.	REV. 1 OF 1